

Shenzhen Shining Future LED Technology Co., Ltd.

Address: Floor 5, Zhongguangxian Business Center, No. 15, Chuangye 2nd Road, Baoan Dist.,
Shenzhen, Guangdong, China (Mainland)
Website: www.sfleds.com
<http://sfleds.en.alibaba.com/>

Contact: Linda Tan
Wechat: baiyunansang Whatsapp: 13713977051
Email: linda@sfleds.com

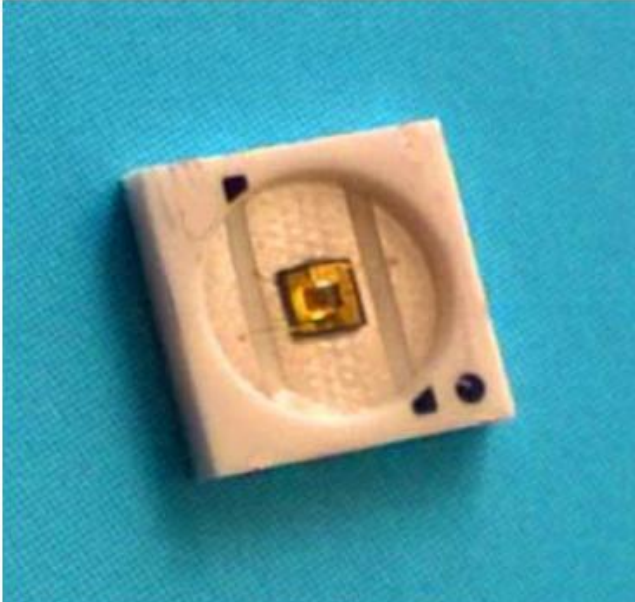

ATTENTION
OBSERVE PRECAUTIONS
FOR HANDLING
ELECTROSTATIC
DISCHARGE
SENSITIVE
DEVICES

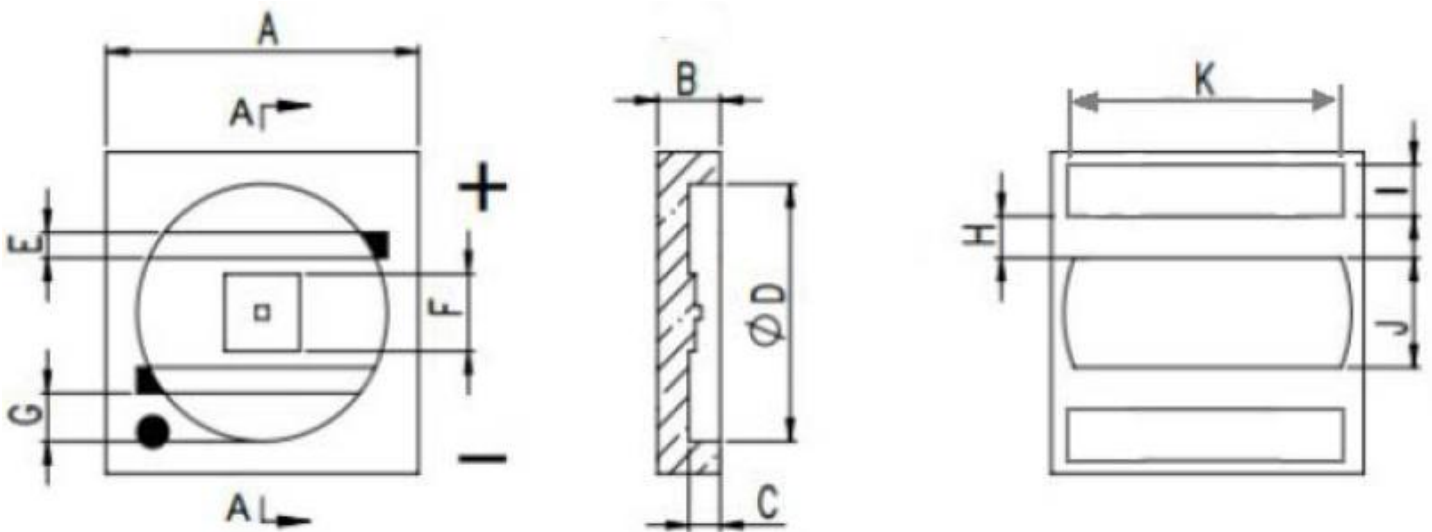

尺寸明细 (mm)											
编号	A	B	C	D	E	F	G	H	I	J	K
尺寸 (mm)	5	1	0.5	4	0.4	1.2	0.75	0.65	0.8	1.7	4

Note: Product picture & dimensions are for reference only. Detailed information is in accordance with the final product.

1. Absolute Maximum Ratings at $T_A = 25^\circ\text{C}$

	Unit	Max
Input Power	mW	200
Operation Current (CW)	mA	20
Operation Current (Pulsed $<5\mu\text{s}$, 1kHz)	mA	100
Operation Voltage	V	8 (CW), 10 (Pulsed)
Operation Temperature	$^\circ\text{C}$	-30~+55
Storage Temperature	$^\circ\text{C}$	-30~+55
Humidity (for non-hermitically sealed LED)	%	0~ 80

2. Typical Electrical & Optical Characteristics at $T_A = 25^\circ\text{C}$

Wavelength (nm)	Part No.	Dimension (mm)	Optical Output Power P_o [mW]		Voltage V_F [V]		Viewing Angle 2 θ % [$^\circ$]
			$I_F/20\text{mA}$		min	max	
			min	max			
265 ± 5	sf-UV265-5050C-A	5.0*5.0*1.0	0.2	0.5	5.0~8.0		140
	sf-UV265-5050C-B		0.5	1.0			

3. Optical Characteristics ($T=25^\circ\text{C}$, $I_F=20\text{mA}$)

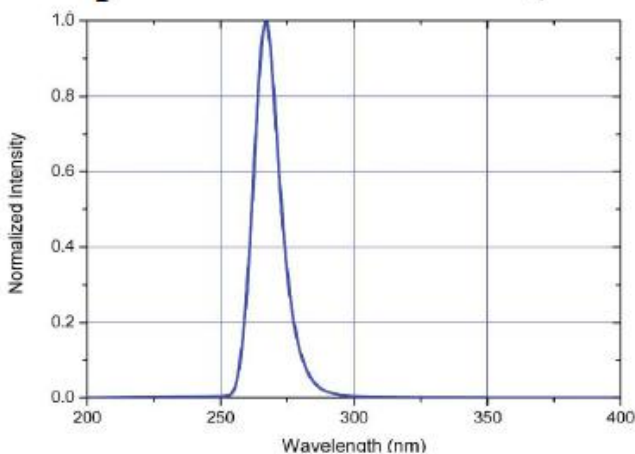

Spectrum

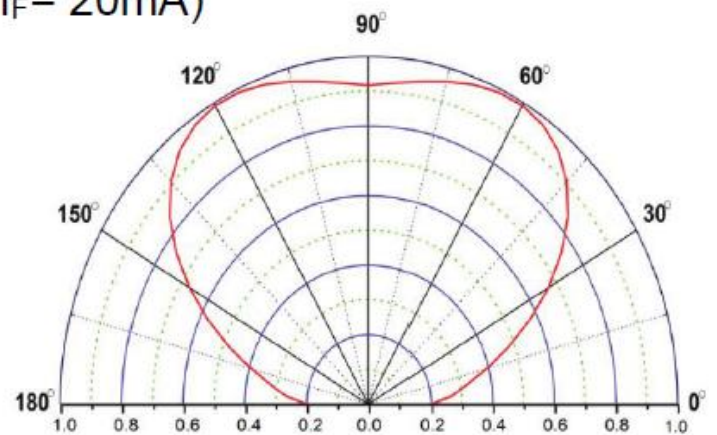

Radiation Patten

4. Electrical Characteristics (T=25°C, I_F= 20mA)

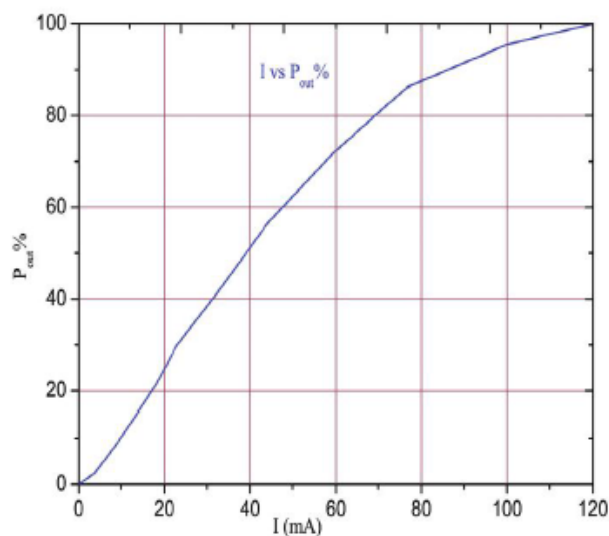

Relative Output v. Current

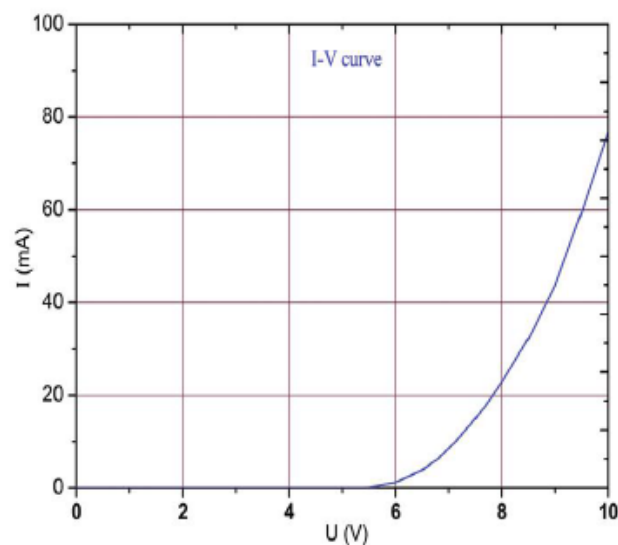

I-V Characteristics

Features:

- ✓ Environmental friendly : No Hg, Cd, Br, Pb
- ✓ Physical sterilization process : High Sterilizing Rate
- ✓ Low energy consumption
- ✓ Long service life

Other Remarks

1. Do not touch the surface of the led, in case to affect the normal emitting.
2. Make sure the right positive and negative pole.
3. Do not watch closely, it is harmful to your eyes.

Shenzhen Shining Future LED Technology Co., Ltd.

Address: Floor 5, Zhongguangxian Business Center, No. 15, Chuangye 2nd Road, Baoan Dist., Shenzhen, Guangdong, China (Mainland)

Website: www.sfleds.com <http://sfleds.en.alibaba.com/>

Contact: Linda Tan

Wechat: baiyunansang Whatsapp: 13713977051

Email: linda@sfleds.com